

Test Cell Integration Solutions...

Dynamometers • Controls
Data Acquisition • Automation



CONTROLS

Inter-Loc V

Modular • Digital • Multi-Loop

What is a Multi-loop Controller?

Dyne Systems has been developing digital dynamometer and throttle controls since 1982. These have been traditional designs with separate dynamometer (Dyn-Loc I through IV) and throttle (DTC-1) control boxes. When it came time to design our next-generation control, we chose to make it a single box that could be either or both – hence, “Multi-Loop Control.” This results in a control that can be configured in many ways, and is ideal for a wide range of applications, including dynamometers (engine, chassis, and electric-motor) and test stands (differential, transmission, gearbox, and others).



Back of Inter-Loc V, showing 3 Modules:

Slot #1 - Throttle Control Module

Slot #2 - Dynamometer Control Module

Slot #3 - Throttle Control Module

Standard Features

Transient Control with Speed and Accuracy: All control loops are updated from 500 to 1000 times per second, providing fast and accurate control.

Configurable: Up to three controller modules (dyno or throttle) can be installed, or added later as test requirements change.

Dynamometer Types: Eddy-Current, AC, DC, Water Brake, Chassis and Dual-Ended Dynamometers.

Throttle Control: Control position of throttle actuator or control device using direct “By-Wire” position and speed control.

Eddy Current Power Amplifier Units: Rack-mountable up to 30 amps. Wall mount up to 200 amps. Maximum 400 VDC.

Feedback Signals: Control speed, torque, throttle position, manifold vacuum, and manifold absolute pressure signals.

Software-Based Design: All major controller functions are implemented in software allowing new features to be developed and easily deployed throughout the life of the product.

Object-Oriented Design: Controller objects, feedback signal objects, fault objects, etc. make the Inter-Loc V easy to configure since all parameters are organized in an intuitive manner.

Configurable General Purpose I/O: Each Inter-Loc V has 15 programmable digital outputs and 5 programmable digital inputs. Also, each installed controller provides 3 programmable analog outputs.

Security: Configuration, tuning, and calibration security is available. The main operator has complete control over which of these features is available to the normal operator.

PLC Compatible Digital I/O: All digital inputs and outputs are standard +24 VDC PLC-style inputs and outputs.

Optical Isolation: All inputs and outputs are optically isolated to improve overall system reliability.

Hardware ESTOP: All Emergency Stop (ESTOP) functionality is implemented entirely in hardware. No computer intervention is required to shut down the test system.

Simple, Reliable Hardware Interfaces: All connector pinouts have been optimized to simplify wiring.

Special Features

Inertia Simulation: Each dynamometer controller can measure applied torque and control rotational acceleration based on a user-specified inertia value.

Road Load and Cooldown: Each dynamometer controller can control a chassis dynamometer in order to simulate road conditions (i.e. wind losses, road grade, etc.) on a vehicle under test. Automated coastdown testing can also be performed.

Differential Testing: A unique setpoint entry interface is available to simultaneously send speed setpoints to two dynamometer controllers connected to the axles of a differential.



Actuator Stand and Remote
Throttle Control from outside
the test cell

www.dynesystems.com

Dynamometer Control Module Features

- Closed-loop control of speed or torque for all types of dynamometers
- Inputs for various types of speed transducers, including magnetic pickups, optical encoders, or any TTL level clock signal
- Inputs for various types of torque transducers, including low-level signal inputs for four and six wire strain gage load cells and high-level signal inputs for in-line torque transducers and torque flanges
- External or Internal Shunt calibration of torque transducers
- Software selectable units for ease of changing from N-M to lb-ft; KW to HP; RPM to MPH, etc.

Engine Throttle Control Module Features

- Closed-loop control of throttle position, engine speed, engine torque, manifold absolute pressure (MAP), manifold vacuum, or engine throttle position (feedback from engine throttle position sensor [TPS])
- Optional remote operator control station lets you set throttle actuator travel points from a convenient location near the engine, not from the control room.
- Dyne systems' servo-motor based high-resolution digital actuator provides high-torque, high-speed throttle control of engines with mechanical throttles.
- Direct Engine control Module input ("By Wire") control is available with each Throttle Module.

Operator Control Station



The Inter-Loc V's Operator Control Station includes a full VGA active matrix color LCD with touchscreen interface, and only uses 5¼ inches of rack space. Also available in a console. An Inter-Loc V Operator Control Station can be purchased to monitor each controller module that is installed in the Inter-Loc V, or a single Operator Control Station can be used to monitor all installed control modules.



Setup Menu: Interface allows easy configuration

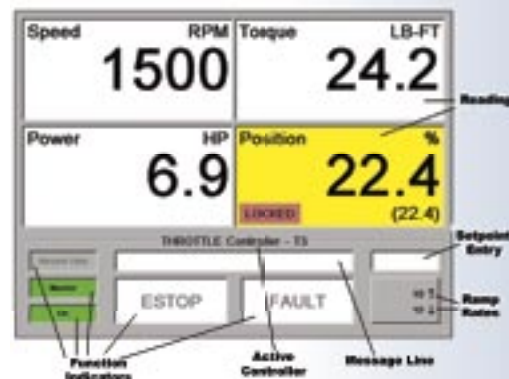

OCS Touchscreen Interface showing Throttle Controller

Interface Options

In addition to the manual control provided by the Operator Control Station, automated control of the Inter-Loc V is available using Dyne Systems' powerful data acquisition and control software - Cell Assistant for Windows™. Or, develop your own control software using Dyne Systems' Inter-Loc V SDK (Software Developers Kit) or other popular software packages such as LabView.

Modular Hardware Components

- Main control CPU
- Dynamometer Control Boards
- Throttle Control Boards
- Eddy Current PAUs
- Operator Control Stations (OCS)
- Water Brake Control Boards
- Throttle Actuator PAUs
- Servo-Motor Actuators
- Remote Control Systems

Digital Control: Precise, Repeatable, Stable

Dyn-Loc IV

Digital Dynamometer Controller

The Dyn-Loc IV is designed to provide precise, repeatable and stable Eddy current or DC dynamometer control. Digital leverwheel switches assure quick and accurate selection of setpoints.

Digital control also gives you zero percent regulation and drift, and that means no analog control loop regulation and drift errors. Digital reference and feedback yield 100% repeatability.

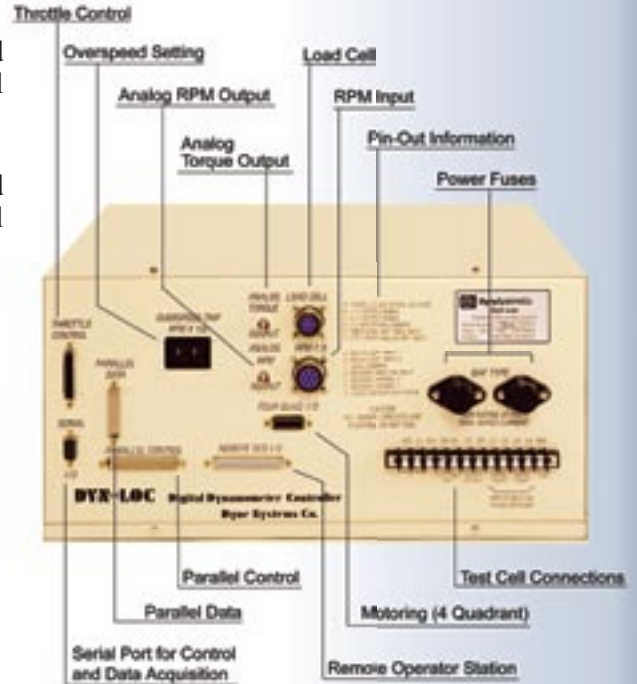

Enclosure: 19" x 8.75" x 13" Rack, Pedestal or Desk Mounted. Color: Ivory Beige

Power Requirements: Input: 120/240 VAC @0.1 A, Control Power, 1/2 A PCB fuse. 240/277 VAC @ 16 A max., Field Coil Power. Rear panel fuses for field power. **Field Output:** 16 A @220 VDC; higher ratings available.

DTC-1

Digital Throttle Controller

The precision and flexibility of the DTC-1 Throttle Control make it the easy choice for your complete engine throttle control needs. RPM, torque, position, MAP and manifold vacuum are controlled with digital precision to +/-1 unit accuracy, with long-term stability and 0% drift. Position is sensed by an optical encoder, to .005%.

The DTC-1 is the upper unit shown at right. Teamed with the Dyne Systems Dyn-Loc IV dynamometer controller (lower unit pictured), all provisions are made for reference and feedback data, instrumentation, and automation control.

Sixteen sets of PID parameters allow the DTC-1 to be adjusted to variations in engine under test or in engine operating point. It utilizes the remote actuator stand as shown at the bottom of page 3.

Mechanical: 19" w x 7" h x 13" d for Rack, Pedestal or Desk Mounting. Color: Ivory Beige. Forced air ventilation at 6 CFM.



Please contact the Sales Group for more complete information on these and other fine products.



W209N17391 Industrial Dr.
Jackson, Wisconsin 53037
Toll Free: (800)657-0726
E-mail Sales: sales@dynesystems.com
Visit Us on the Web at www.dynesystems.com