

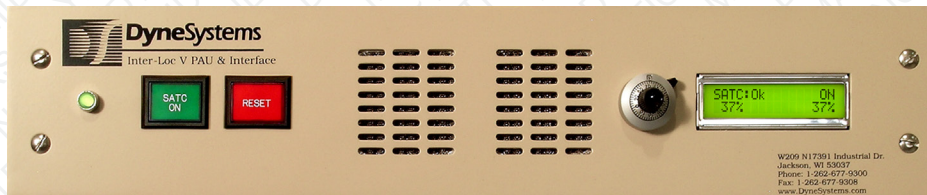

# DyneSystems, Inc.

## Midwest & Dynamatic Dynamometers



## DS830A Stand-Alone Throttle Controller USER MANUAL

Job # \_\_\_\_\_

Model # \_\_\_\_\_

Serial # \_\_\_\_\_

# From Dyne Systems, Inc.

The DS830A Standalone Throttle Controller (SATC) is a standalone actuator/throttle position controller. It is designed to control the position of any current Dyne Systems, Inc. (DS) actuator as well as the older high-speed and high-torque actuators. No other actuators are officially supported, although some may work. The user-friendly SATC is designed to operate in one of two configurations: standalone or with an external control system. These two configurations are described in Section 2 of this manual.

## Feature Summary:

- The LCD display shows position command, actual position, SATC status, and fault information.
- Sub-D connections are used to interface with external equipment.
- Two modes of operation: Standalone Mode and External Control Mode.
- Two position command input types: 0 to +10 VDC or 0 to +20 mA.
- Position Feedback is available as a 0 to +10 VDC output.
- Control inputs and status/fault outputs offered at PLC-level (ie: 24 VDC).
- Fault detection (e.g. actuator stall, power fail, etc.).
- Field configurable (between Standalone and External Control Modes).

This manual is intended for use by qualified personnel only. All DS approved drawings (if included) and specific instructions for this equipment must take precedence over general information contained in this manual.

Thank you for purchasing this product from DS. Our staff is at your disposal. Should you need information or support that is not found in this manual, please call (800) 657-0726.



**CONTROLS, DYNAMOMETERS, SYSTEM INTEGRATION AND TEST CELL AUTOMATION**

Dyne Systems, Inc. • W209 N17391 Industrial Drive • Jackson, Wisconsin 53037

Toll Free: 800.657.0726 • [www.dynesystems.com](http://www.dynesystems.com)



# TABLE OF CONTENTS

<b>SECTION 1:</b>	<b>GENERAL INFORMATION</b>	<b>4</b>
	SAFETY .....	4
	RECEIVING INSPECTION .....	4
	DAMAGE CLAIMS .....	4
	IDENTIFY YOUR SATC.....	5
	TRAINING.....	5
<b>SECTION 2:</b>	<b>CONFIGURATIONS</b>	<b>6</b>
<b>SECTION 3:</b>	<b>INSTALLATION ENVIRONMENT</b>	<b>7</b>
<b>SECTION 4:</b>	<b>INSTALLATION</b>	<b>8</b>
	MOUNTING .....	8
	ELECTRICAL CONNECTIONS .....	8
<b>SECTION 5:</b>	<b>CONNECTIONS</b>	<b>9</b>
	SUB-D CONNECTORS .....	9
	MS CONNECTORS .....	12
<b>SECTION 6:</b>	<b>JUMPERS</b>	<b>13</b>
<b>SECTION 7:</b>	<b>OPERATION</b>	<b>14</b>
	FRONT PANEL DISPLAY.....	14
	DIGITAL AND ANALOG I/O.....	15
<b>SECTION 8:</b>	<b>CALIBRATION</b>	<b>17</b>
	CALIBRATION USING THE REMOTE STATION .....	17
	SETTING LOWER AND UPPER LIMIT.....	18
	CALIBRATION USING AN EXTERNAL CONTROL SYSTEM.....	20
<b>SECTION 9:</b>	<b>ACTUATOR SUMMARY</b>	<b>21</b>
<b>SECTION 10:</b>	<b>PRODUCT WARRANTY</b>	<b>22</b>
<b>APPENDIX A:</b>	<b>DEFINITIONS / FORMULAS</b>	<b>23</b>
<b>APPENDIX B:</b>	<b>ACRONYMS</b>	<b>24</b>

## SECTION 1: GENERAL INFORMATION

Dyne Systems, Inc. (hereafter referred to as DS) is the sole Original Equipment Manufacturer (OEM) of the DS830A Standalone Throttle Controller (SATC). This manual, intended for qualified personnel only, contains instructions for proper handling, installation, operation, and maintenance of the SATC. All DS approved drawings (if included) and specific instructions for this equipment must take precedence over general information contained in this manual.

All inquiries related to the SATC should be directed to DS at (800) 657-0726.

### SAFETY

**Read your User Manual!** Electrical equipment can be dangerous with the potential to cause injury or death if operated and/or installed incorrectly. Become familiar with all safety instructions and procedures. WARNING, CAUTION, WARRANTY and NOTE labels are used throughout the manual to remind you of the hazards that exist. Know your equipment before handling or working on it.



*used to warn of the possibility of injury to personnel and damage to equipment*



*used to caution of potential hazards and unsafe practices*



*used to alert to items that affect Warranty*

**Note:** *used for special instructions related to safety, proper operation or maintenance*

### RECEIVING INSPECTION

Upon arrival of your equipment, check all items received against the packing slip to ensure the shipment is complete. Then inspect for damage. Any evidence of rough handling may be an indication of hidden damage.

The following checks are offered to aid your inspection:

1. Inspect packaging and skid(s) for any mistreatment. Document and photograph any signs of damage.
2. Inspect housing to ensure there is no damage and that the unit is intact.

### DAMAGE CLAIMS

In the event of damage, report it without delay to the Carrier and DS. DS's warranty policy does not cover shipping damage or lost material. It is important to file a damage claim with the Carrier promptly. If you require assistance in settling the claim, contact DS. Refer to equipment by Purchase Order, Model, and Serial Number, as shown on the nameplate of the unit involved.

## IDENTIFY YOUR SATC

The DS830A Standalone Throttle Controller (SATC) was configured at DS for your specific application. Review the diagrams and verify you have the correct configuration:

- Standalone
- External Control

Locate the model and serial numbers on the SATC, and verify that they are the same as that shown on the cover of this manual. This information should be used when contacting DS customer support.

## TRAINING

Training programs are an essential part of safe and correct operation. Training provides the know-how necessary to obtain top performance from your equipment. DS recognizes the fact and will conduct training classes on-site or at the factory to educate personnel in safe operating and maintenance procedures.

## SECTION 2: CONFIGURATIONS

Two modes of operation are supported: (1) Standalone and (2) External Control.

### Standalone Mode

In the Standalone Mode of operation, On/Off and Reset buttons are provided on the front panel. An analog potentiometer is also provided on the front panel to supply the user with actuator position control. In this mode, the SATC must be located such that the LCD display can be easily viewed by the operator. The display is the operator's only feedback regarding the user-defined actuator position command as well as the actual actuator position. The LCD is also the operator's only source of fault/status feedback.

The SATC, when functioning as a standalone controller, requires the use of a remote station. This remote station is the user interface when calibrating the actuator and may be helpful when the display is out of view. DS offers this remote station as part of the actuator package.

**Note:** *When using the SATC in a stand-alone configuration, the Soft Shutdown (SSD) input (Pin 15) within the "THROTTLE CONTROL" connector must be jumped to 24VDC (Pin 6). This ignores the SSD request normally given by the external control system.*

### External Control Mode

In the External Control Mode, all front panel pushbuttons and potentiometers are provided, but are not required to function. The external control system provides the On/Off and Reset input commands. Similarly, the analog position command, 0 to +10VDC or 0 to 20mA, is provided by an external supply, acting as an input position command. Although not imperative, it is still helpful to locate the SATC such that the LCD is visible. Status and position information is provided to the external control system for display elsewhere, but it is also still displayed by the LCD.

**Note:** *Detailed fault information is only available on the SATC's LCD display, fault information is not provided to the external control system.*

**Note:** *When using an external control system, the front panel buttons continue to function but are not needed. The jumper between Pins 5 and 6 must be removed within the "AUX" connector. The removal of this jumper renders the potentiometer inoperable, allowing for external control through the "THROTTLE CONTROL" connector without conflict.*

When used in conjunction with an external control system, calibration can be done without the use of the DS remote station. However, the remote station can still be used, and can prove to be beneficial. With a remote station, calibration can be performed away from the SATC display. The remote station is offered as an option when an external control system is being used.

**Note:** *When using an external control system without a DSI remote station, the Soft Shutdown (SSD) input (Pin 8) within the "REMOTE BASIC" connector must be jumped to 24VDC (Pin 1). This ignores the SSD request normally given by the DSI remote station.*

## SECTION 3: INSTALLATION ENVIRONMENT

The SATC should be mounted so it is not exposed to severe shock and/or vibrations. If adverse conditions are anticipated, the SATC can be mounted using vibration-damping materials.

The atmosphere should be free of corrosive gases.

The atmosphere should be free of vapors or powders that could cause fire or explosion.

Relative humidity should be 0% to 95%, non-condensing.

Temperature range should be 32 °F – 90 °F (0 °C – 32.2 °C).

# SECTION 4: INSTALLATION

## MOUNTING

The SATC comes in a 3.5”h x 17”w x 15”d enclosure that is designed to fit into a standard 19” rack mount enclosure. DS provides rack mount brackets for proper installation. Unless previously specified, the end user is responsible for providing the mounting system.

**Note:** *The SATC requires air to circulate through its enclosure for proper cooling. Be sure to provide some space at the front and rear of the enclosure to allow air flow.*

## ELECTRICAL CONNECTIONS

Connections may vary with different configurations; all electrical connections should correspond with the schematic provided by DS at time of delivery. General connection information is provided to show the location of all possible connections to the SATC, for pin-outs of all connections, refer to Section 5 - Connections.

**Note:** *Only a qualified electrician should install the SATC. All installations should comply with the most current version of the National Electric Code (NEC) as well as all local codes and regulations.*

Refer to Figure 4.1 for SATC rear panel connector locations.

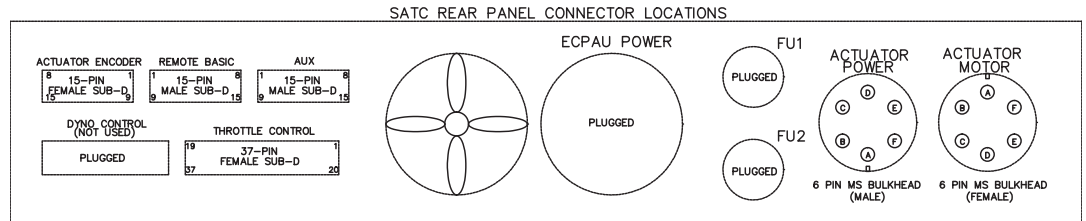

Figure 4.1 - SATC Rear Panel Connector Locations

## SECTION 5: CONNECTIONS

The SATC has four Sub-D Connectors and two 6-Pin MS Connectors that interface with external devices.

All of the digital Inputs and Outputs (I/O) use PLC-level (i.e. +24 VDC) logic. +24 VDC is provided in many connectors; thus, the external control system only needs to process the +24 VDC, and supply it back into the desired inputs via dry contact relays.

### SUB-D CONNECTORS

**ACTUATOR ENCODER (15-Pin Female Sub-D): Actuator Position Feedback**

Pin #	Function	Comments
1	Common	Encoder Common
2	5VDC (o)	Encoder Power
3	A (i)	Encoder Signal A
4	A' (i)	Encoder Signal A Not
5	B (i)	Encoder Signal B
6	B' (i)	Encoder Signal B Not
7	ILK (i)	Encoder Operation Feedback
8	NC	Not Connected
9	Common	Encoder Common
10	5VDC (o)	Encoder Power
11	A (i)	Encoder Signal A
12	A' (i)	Encoder Signal A Not
13	B (i)	Encoder Signal B
14	B' (i)	Encoder Signal B Not
15	ILK (i)	Encoder Operation Feedback

Table 5.1

**REMOTE BASIC (15-Pin Male Sub-D): Remote Station Control**

Pin #	Function	Comments
1	24VDC (o)	Remote Station Power
2	Common	Remote Station Common
3	Button_Up (i)	Remote Station Up Button
4	LED_Lower (o)	Remote Station Lower Limit LED Indicator
5	LED_Upper (o)	Remote Station Upper Limit LED Indicator
6	Button_Down (i)	Remote Station Down Button
7	LED_Accept (o)	Remote Station Accept Limit LED Indicator
8	Button_Soft_Shutdown (i)	Remote Station Soft Shutdown Button
9	24VDC (o)	Remote Station Power
10	Common	Remote Station Common
11	NC	Not Connected
12	NC	Not Connected
13	NC	Not Connected
14	Button_Enter (i)	Remote Station Enter Button
15	LED_Fault (o)	Remote Station Fault LED Indicator

Table 5.2

## SUB-D CONNECTORS (CONTINUED)

**AUX (15-Pin Female Sub-D): External Position Command Input/Position Feedback**

Pin #	Function	Comments
1	Input Common	Position Command Input Signal Common
2	Feedback Common	Actual Position Feedback Common
3	NC	Not Connected
4	NC	Not Connected
5	Position Input (POT)	Position Input Voltage from Front Panel Potentiometer. (Jumped to Pin #6 when used)
6	Position Input Signal (i)	Position Command Input Signal, Jumped to Pin #5 for use with the Front Panel Potentiometer.
7	Position Feedback Signal (o)	Actual Position Feedback
8	NC	Not Connected
9	NC	Not Connected
10	NC	Not Connected
11	NC	Not Connected
12	NC	Not Connected
13	NC	Not Connected
14	NC	Not Connected
15	NC	Not Connected

**Table 5.3**

**THROTTLE CONTROL (37-Pin Female Sub-D): Customer Supplied External Control Interface**

<b>Pin #</b>	<b>Function</b>	<b>Comments</b>
1	Position Command (i)	Position Command Input Voltage from External Control System
2	Ai Common	Analog Common (+/- 15VDC)
3	Actuator On (i)	Actuator On/Off Control Input from External Control System
4	(Pi) Power Common	Power Common (+24VDC)
5	(Pi) Power Common	Power Common (+24VDC)
6	Power (+24VDC) (o)	Output Power (+24VDC) to system safeties/ controls.
7	NC	Not Connected
8	Actuator Position Feedback (o)	Actual Actuator Position Feedback Signal
9	Ai Common	Analog Common (+/- 15VDC)
10	NC	Not Connected
11	(Pi) Power Common	Power Common (+24VDC)
12	Remote Up Push Button (i)	Remote Push Button for Up Command (Used for calibration)
13	Remote Down Push Button (i)	Remote Push Button for Down Command (Used for calibration)
14	Remote Enter Push Button (i)	Remote Push Button for Enter Command (Used for calibration)
15	Remote Soft Shutdown Push Button (i)	Remote Push Button for Soft Shutdown (Used for calibration; also functions while system is in use)
16	NC	Not Connected
17	NC	Not Connected
18	NC	Not Connected
19	NC	Not Connected
20	Ai Common	Analog Common (+/- 15VDC)
21	Reset Command (i)	Reset Command from External Control System
22	NC	Not Connected
23	SATC On Feedback (o)	SATC On Feedback to External Control System
24	SATC OK Feedback (o)	SATC OK Feedback to External Control System
25	Power (+24VDC) (o)	Output Power (+24VDC) to system safeties/ controls.
26	NC	Not Connected
27	Ai Common	Analog Common (+/- 15VDC)
28	NC	Not Connected
29	(Pi) Power Common	Power Common (+24VDC)
30	Remote Upper LED (o)	Remote LED to indicate the Upper Limit Set during Calibration
31	Remote Lower LED (o)	Remote LED to indicate Lower Limit Set during Calibration
32	Remote Accept LED (o)	Remote LED to indicate the Acceptance of the newly entered limits
33	Remote Fault LED (o)	Remote LED to indicate that the system has faulted
34	NC	Not Connected
35	NC	Not Connected
36	NC	Not Connected
37	NC	Not Connected

**Table 5.4**

## MS CONNECTORS

**ACTUATOR POWER (6-Pin Male MS Connector): Input Power (120VAC)**

Pin #	Function	Comments
A	Hot 120VAC Input (i)	Hot 120VAC Input Power
B	Neutral 120VAC (i)	Neutral 120VAC Input Power
C	GND	Ground
D	NC	Not Connected
E	NC	Not Connected
F	NC	Not Connected

**Table 5.5**

**ACTUATOR MOTOR (6-Pin Female MS Connector): Output Actuator Power**

Pin #	Function	Comments
A	(+) Actuator Armature (o)	Positive Actuator Output Power
B	NC	Not Connected
C	NC	Not Connected
D	(-) Actuator Armature (o)	Negative Actuator Output Power
E	(-) Actuator Armature (o)	Negative Actuator Output Power
F	(+) Actuator Armature (o)	Positive Actuator Output Power

**Table 5.6**

## SECTION 6: JUMPERS

Jumpers are installed at DS before shipment per the customer's specified configuration. However, Table 6.1 may be needed for future additions to a system, or for troubleshooting a system.

Jumper	Function
JP1	Position command type
	IN = 0 to +20 mA current
	OUT = 0 to +10 VDC voltage
	OUT = DEFAULT
JP2	Install to connect the (-) terminal of the differential input amplifier to COMMON
	IN = Single-Ended input operation
	OUT = Differential input operation
	IN = DEFAULT
JP3	IN = Override Soft Shut Down input from external controller
	OUT = Accept Soft Shut Down input from external controller
	OUT = DEFAULT
JP4	IN = Override Soft Shut Down input from possible front panel input
	OUT = Accept Soft Shut Down input from possible front panel input
	IN = DEFAULT (As no front panel Soft Shut Down is offered on this model)
JP5	IN = Override Soft Shut Down input from Remote Station box
	OUT: Accept Soft Shut Down input from Remote Station Box
	OUT = DEFAULT
JP6 – JP9	Solid wire. Cannot be removed.

Table 6.1 - Jumpers

# SECTION 7: OPERATION

## FRONT PANEL DISPLAY

The front panel display layout is shown below:

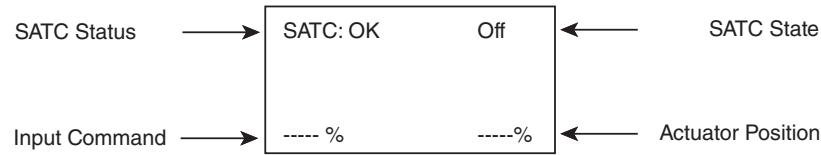

Figure 7.1 - Example of Main Screen

The upper-left value displays the operational status of the system. When operating properly, the SATC will always read “OK” or “Reset”. When the SATC is in a fault condition, an entirely different screen is displayed describing the fault.

The upper-right value displays the current operating state. The SATC state will always read “Off”, “ON”, SSD (Soft Shutdown) or “RTZ” (Return To Zero). The SSD and RTZ states can only be cleared by a reset; however, the reset is ignored until the SSD/RTZ has completed or 5 seconds has expired (whichever occurs first).

The lower-left value displays the commanded (input) position as a percentage of the total input range.

The lower-right value displays the actual actuator position as a percentage of the total actuator range.

**Note:** When the SATC is in a fault condition, an entirely different screen from the one above is displayed describing the fault. An example of a fault screen is shown below.

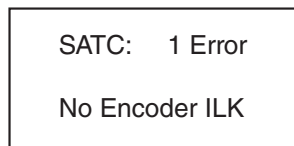

Figure 7.2 - Example of Fault Screen

## DIGITAL AND ANALOG I/O

**Note:** As stated in a previous section, all digital I/O is +24VDC (PLC Level) logic.

### Inputs

The SATC is entirely controlled via digital and analog inputs. In a standalone configuration, these inputs are directly wired to the front panel's pushbuttons and potentiometer. When used in conjunction with an external control system, the control system commands all inputs, hence the front panel controls are no longer required to function.

All connections that can be used with an external system are described in the Section 5 - Connections. The "Actuator ON" input is used to enable/disable the SATC. The "Reset" input is used to clear fault conditions.

**Note:** The "SOFT SHUTDOWN" button on the Remote Station is also a valid active input. When pressed, the SATC will enable itself (if not already enabled), will return the actuator to the zero position, and finally will disable itself. The resulting SSD condition is NOT a fault; however, it does prevent the SATC from being re-enabled and must be cleared out via a "Reset" command.

**Note:** To minimize/eliminate the effects of offset voltages at the analog position command input, the SATC ignores all command voltages less than 20 mV (i.e. 0.2% position).

### Outputs

When using an external control system, several digital outputs are available that annunciate the state of the SATC. All digital outputs are made available through the "THROTTLE CONTROL" connector as described in Section 5 - Connections. These outputs can either be used by the external control system, or they can be wired directly to 24VDC lamps to indicate the status of the SATC.

**Note:** Each 24VDC output can source up to 1A, with a limit of 1A available for all outputs combined.

A 0 to +10 VDC analog position feedback output is also available at the "AUX" connector, as described in Section 5 - Connections. This output indicates the throttle position to an external control system or other customer defined indicator. This output is reasonably accurate; however, if used by an external control system, the external control system should zero and span the position feedback as needed to attain the desired accuracy.

## DIGITAL AND ANALOG I/O (CONTINUED)

### Faults

When a fault occurs, the SATC performs one of two actions (depending on the type of fault). Some faults cause the actuator to return to the zero position (i.e. RTZ) and then disable the SATC. Other faults simply disable the SATC and leave the actuator position as is (usually to prevent damage to the SATC). After resolving the fault condition, the SATC can be cleared by issuing a reset command.

**Note:** Detailed fault descriptions are available via the LCD display only.



*The actuator may remain at previous position even after clearing and resetting some faults. Use caution when restarting the system as the throttle may still be set at the previous position.*

Fault	Action	Cause
RTZ Input	RTZ	+24 VDC is no longer present at the RTZ input. This fault input condition is usually caused by the external control system.
No Encoder ILK	Disable	The actuator cable is disconnected or there is an issue with the connection. There may be issues with the internal encoder assembly.
Invalid Span	Disable	The actuator is improperly calibrated. This fault occurs only when the operator attempts to enable the SATC. Successfully re-calibrate the upper and lower limits to eliminate this fault.
Over-Temperature	Disable	The H-Bridge is too hot. Wait for the SATC to cool. Most likely caused by rapid actuator movement for a long period of time.
Over-Current	Disable	Usually occurs along with the "Actuator Stalled" fault (listed below) since excessive currents are mainly caused by stalled actuators.
Power Fail	RTZ	The head supply voltage has fallen below +20 VDC. This fault always occurs when the SATC is powered down.
Actuator Stalled	Disable	Actuator movement is blocked. Could also occur due to improper calibration of upper and lower limits.

**Table 7.1 - Faults, Actions and Causes**

## SECTION 8: CALIBRATION

Actuator calibration is a critical part of the overall operation of the SATC. It is vital that the Upper and Lower Limits of the actuator movement be correctly set and periodically adjusted to compensate for drift. Calibration can be initiated, performed, and saved using the two following methods; (1) using the pushbuttons on the Remote Station (2) using the I/O provided through the “THROTTLE CONTROL” connector.

**Note:** *It is assumed that the LCD display is visible during calibration when using the Remote Station; however, this is not a requirement. Familiarity with the calibration procedure, combined with feedback to the operator (via the LED's on the Remote Station) ultimately allows calibration to be performed with only the Remote Station in hand (and the LCD display not necessarily visible).*

### CALIBRATION USING THE REMOTE STATION

#### Initiating Calibration

To begin calibration, supply main power to the SATC but do not enable the actuator. Press and hold the “ENTER” button (on the Remote Station) for 2 seconds, the SATC will then enter calibration mode. When in this mode, the LCD will display “SET LOWER” as the first calibration menu item and all four LED's on the Remote Station will flash several times. To ensure proper operation of the actuator the following menu items must be addressed during calibration “Lower Limit,” “Upper Limit,” and direction of rotation. These limits must also be tested and saved before exiting the set up menu.

**Note:** *To navigate through the calibration menu, press the “UP” and “DOWN” buttons to cycle through the menu items. Press the “ENTER” button to select the desired task.*

**Note:** *The “Lower” and “Upper” limits are defined as the maximum allowable distance of travel by the actuator arm in a given direction (Up or Down).*

Table 8.1 lists the headings within the calibration menu along with the LED indication at that point within the menu.

Calibration Task	LED status	Description
SET LOWER	LOWER LIMIT = ON	Set the lower limit (i.e. 0% position)
SET UPPER	UPPER LIMIT = ON	Set the upper limit (i.e. 100% position)
TEST LIMITS	All are OFF.	Test limits by jogging the actuator.
EXIT & SAVE	ACCEPT LIMIT = blinks FAULT = blinks	
EXIT & CANCEL	FAULT = blinks	
DIRECTION	All are OFF.	Define direction of actuator movement, viewed from shaft end, when moving from 0% to 100% position. Selections are: Clockwise-CW Counter Clockwise-CCW Note: If the actuator moves opposite to the configured direction, there is a wiring error in the SATC. Contact DS.
MOVEMENT TYPE	All are OFF.	Selects the type of actuator movement during calibration. Manual - move actuator by hand Powered - use UP and DOWN buttons

Table 8.1

## Choosing Direction of Rotation

To select the direction for the actuator, navigate to the “DIRECTION” menu item, press the “ENTER” button and select the desired direction. Press “ENTER” again to accept the direction.

## Choosing Calibration Movement Type

To select the type of Calibration (Powered or Manual), navigate to the “MOVEMENT TYPE” menu item, press the “ENTER” button and select the desired type of calibration. Press “ENTER” again to accept the type.

**Note:** *Powered and Manual calibration types are discussed in the next sub-section.*

## SETTING LOWER AND UPPER LIMIT

### Powered Calibration

When setting the upper and lower limits using “Powered” calibration, follow the below procedure.

1. Navigate to the appropriate menu item (SET LOWER or SET UPPER) and press the “ENTER” button to begin the setup.
2. Press the “UP” and “DOWN” buttons to cause small movements in the actuator position. Holding these buttons down causes the actuator to move rapidly (i.e. slew) in the respective direction.
3. When the new Upper (or Lower) limit is established, press the “ENTER” button. On the remote station, both the “ACCEPT” and respective “LOWER” or “UPPER” LED will turn on. This indicates a successful setting of the limit.
4. Press “ENTER” again to accept the limit.
5. Repeat this process to complete the calibration of both the upper and lower limits.

### Manual Calibration

When setting the upper and lower limits using “Manual” calibration, follow the below procedure.

1. Navigate to the appropriate menu item (SET LOWER or SET UPPER) and press the “ENTER” button to begin the setup.
2. Move the actuator, free hand, to the desired position. The “UP” and “DOWN” buttons on the Remote Station are no longer functional.
3. When the new Upper (or Lower) limit is established, press the “ENTER” button. On the remote station, both the “ACCEPT” and respective “LOWER” or “UPPER” LED will turn on. This indicates a successful setting of the limit.
4. Press “ENTER” again to accept the limit.
5. Repeat this process to complete the calibration of both the upper and lower limits.

## LCD display during calibration

If visible, the LCD display offers valuable feedback during calibration. When setting the upper or lower limit, the position of the actuator is shown as a count. When a desired set-point is reached and selected, the following acceptance screen is displayed.

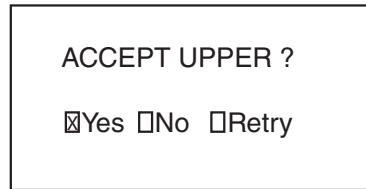

**Figure 8.1 - Calibration Display**

The default selection is set to "Yes." Press the "UP" and "DOWN" buttons to change the selection to "No" or "Retry" as needed. Press the "ENTER" button to make the desired selection (usually "Yes").

As shown in the ACTUATOR SUMMARY section (Section 9), each DS actuator has an encoder count range. The new lower and upper limits being set must be within the range specified for the actuator. If the encoder count range of the selected actuator is not reached or exceeded, the LCD will display an appropriate error message (shown below).

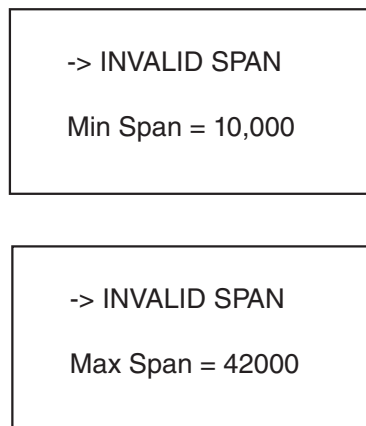

**Figure 8.2 - Actuator Summary Displays**

To fix an invalid limit, use the "DOWN" button to navigate back to the desired menu item and go through setting that limit again.

Testing of the lower and upper limits is not available until limits have been set within the specified encoder count range.

**Note:** *If the standard DS actuator stop-plate is installed (highly recommended), it is impossible to create excessively large span values. Insufficient span is the most frequently occurring error.*

## Testing the lower and upper limits

After navigating to the “TEST LIMITS” menu item, hit “ENTER.” Once in the menu, press and hold the “ENTER” button to rotate the actuator towards the Upper limit (i.e. the 100% position). Release the “ENTER” button to allow the actuator to rotate back towards the Lower limit (i.e. the 0% position). After successfully spanning the limits, press the “SOFT SHUTDOWN” button to return to the main calibration menu.

## Saving new limits

To save the new Lower and Upper limits, navigate to the “EXIT & SAVE” menu item and press “ENTER.”

## Exiting without saving new limits

To exit the calibration menu without saving new limits, navigate to the “EXIT & CANCEL” menu item and press “ENTER.”

## CALIBRATION USING AN EXTERNAL CONTROL SYSTEM

The same procedure is followed when calibrating using an external control system. However, the control that was provided by the Remote Station now must be provided by the external control system. This control is interfaced with the SATC via the “THROTTLE CONTROL” connector. Refer to Section 5 - Connections for information on the “THROTTLE CONTROL” connector.

## SECTION 9: ACTUATOR SUMMARY

Over the years, DS has used three different actuators. The latest actuator is the “ACTUATOR-03” standard model. The SATC can be used with all three actuators. Be sure that the actuator in use is listed below, otherwise calibration faults and other issues may occur.

The Table 9.1 shows all three DS actuators and some of their specifications.

Actuator	Voltage (Volts)	Encoder (PPR)	Max Move Rate %/sec	Gear Ratio	Nominal Counts	Minimum Counts	Maximum Counts
Standard	24	200	200	246:1	38,000	10,000	42,000
Old High-Torque	12	200	400	246:1	38,000	10,000	42,000
Old High-Speed	12	500	700	134:1	52,000	10,000	57,000

Table 9.1

**Note:** SATC units purchased before September 2010 will have higher minimum count requirements for the listed actuators. These requirements are as follows:

- Standard Actuator: 27,000 Counts
- Old High-Torque Actuator: 27,000 Counts
- Old High-Speed Actuator: 36,000 Counts

**Note:** The SATC board will never command movement rates beyond 500%/sec even though the older high-speed actuators are capable of higher rates.

**Note:** If the actuator in use is not listed above please contact DS.

## SECTION 10: PRODUCT WARRANTY

**WARRANTY, REMEDIES AND LIMITATIONS:** DyneSystems warrants the following equipment will conform to published specifications and be free from faulty material or workmanship for the listed time period from date of shipment or onsite repair:

New Controls	12 Months
Repaired Controls	3 Months
Service Calls	3 Months

This warranty covers properly installed equipment used within specified limits and ambient conditions and is limited to repair or replacement of equipment proving defective at DyneSystems. For warranty to be valid, Buyer must conform to DyneSystems' factory specifications. If applicable, terms of Warranty Validation and Delivery Certification must be met for warranty to be valid. This warranty does not apply to experimental, developmental or non-standards Goods and Products which are sold "as is," "where is." DyneSystems shall not be liable for labor costs associated with removing, reinstalling or delivering any equipment. Transportation costs associated with delivering products to DyneSystems under the warranty are the responsibility of the Customer. Transportation costs associated with returning products to the Customer under the warranty are the responsibility of DyneSystems. If warranty service is deemed necessary and product (i.e. controls, small dynamometer, etc) can be shipped to DyneSystems then it is expected that product be sent to DyneSystems; however, if Customer wants warranty work to be performed onsite and DyneSystems deems it feasible then Customer will be responsible for travel hours and travel / transportation costs. DyneSystems is not liable for costs incurred such as loss of work time or production time or for loss of profits or other damages, including, but not limited to consequential damage.

THE FOREGOING WARRANTIES ARE EXCLUSIVE AND ARE GIVEN AND ACCEPTED IN LIEU OF ANY AND ALL OTHER WARRANTIES, EXPRESS OR IMPLIED, INCLUDING WITHOUT LIMITATION, THE IMPLIED WARRANTIES OF MERCHANTABILITY AND FITNESS FOR A PARTICULAR PURPOSE. THE REMEDIES OF BUYER FOR ANY BREACH OF WARRANTY SHALL BE LIMITED TO THOSE PROVIDED HEREIN, AND FOR DELAY OR NON-DELIVERY WHICH IS NOT EXCUSABLE, TO THE PURCHASE PRICE OF THE GOODS IN RESPECT OF WHICH THE DELAY OR NON-DELIVERY IS CLAIMED, TO THE EXCLUSION OF ANY AND ALL OTHER REMEDIES. IN NO EVENT SHALL DYNE SYSTEMS BE LIABLE FOR SPECIAL, INDIRECT OR CONSEQUENTIAL DAMAGES, INCLUDING WITHOUT LIMITATION, LOSS OF USE OR PROFITS. NO AGREEMENT VARYING OR EXTENDING THE FOREGOING WARRANTIES, REMEDIES OR THIS LIMITATION WILL BE BINDING UPON DYNE SYSTEMS UNLESS IN WRITING SIGNED BY A DULY AUTHORIZED OFFICER OF DYNE SYSTEMS. DYNE SYSTEMS' LIABILITY FOR FAILURE TO COMPLY WITH ANY WARRANTY OR REPRESENTATION HEREUNDER SHALL BE LIMITED TO THE VALUE OF THE GOODS SOLD HEREUNDER.

Excluding equipment made for integrated systems supplied or made by DyneSystems, DyneSystems makes no warranty on the use of the equipment in combination with other products or in the practice of any process and if a claim, suit or action is based thereon, Buyer shall defend, indemnify and save DyneSystems harmless therefrom.

**LIMITATION OF LIABILITY:** DyneSystems' liability for defective or nonconforming products, whether based on breach of warranty negligent manufacture or product liability, is exclusively limited to repair or replacement, at DyneSystems' election, of such products. DyneSystems assumes no risk and shall be subject to no liability for any damages or loss resulting from the specific use or application made of the Products. DyneSystems' liability for any other claim, whether based on breach of contract, negligence or product liability, relating to the products shall not exceed the price paid by Buyer for such Products. In no event will DyneSystems be liable for any special, incidental or consequential damages, including loss of use, loss of profit, claims of third parties, or damages arising from bodily injury, or death, however caused, whether by the negligence of DyneSystems or otherwise.

**EQUIPMENT MADE BY OTHERS:** Any items supplied that are not manufactured by DyneSystems are covered by the original manufacturer's warranty and not by a DyneSystems warranty.

**CUSTOMER SUPPLIED PRODUCT:** DyneSystems accepts customer provided equipment as a courtesy only. DyneSystems is not responsible for determining suitability of customer's equipment for a particular purpose. Repair or configuration of customer-supplied equipment will be charged at DyneSystems normal rate.

# APPENDIX A: DEFINITIONS / FORMULAS

## Ohm's Law

Ohm's Law defines the relationships between (P) power, (E) voltage, (I) current, and (R) resistance. One ohm is the resistance value through which one volt will maintain a current of one ampere.

$$I \text{ (Current)} = P \text{ (Power)} / E \text{ (Voltage)}$$

$$I \text{ (Current)} = E \text{ (Voltage)} / R \text{ (Resistance)}$$

(I) Current is what flows on a wire or conductor like water flowing down a river. Current flows from negative to positive on the surface of a conductor. Current is measured in (A) amperes or amps.

(E) Voltage is the difference in electrical potential between two points in a circuit. It is the push or pressure behind current flow through a circuit, and is measured in (V) volts.

(R) Resistance determines how much current will flow through a component. Resistors are used to control voltage and current levels. A very high resistance allows a small amount of current to flow. A very low resistance allows a large amount of current to flow. Resistance is measured in ohms.

(P) Power is the amount of current times the voltage level at a given point measured in wattage or watts.

# APPENDIX B: DRAWINGS AND SCHEMATICS

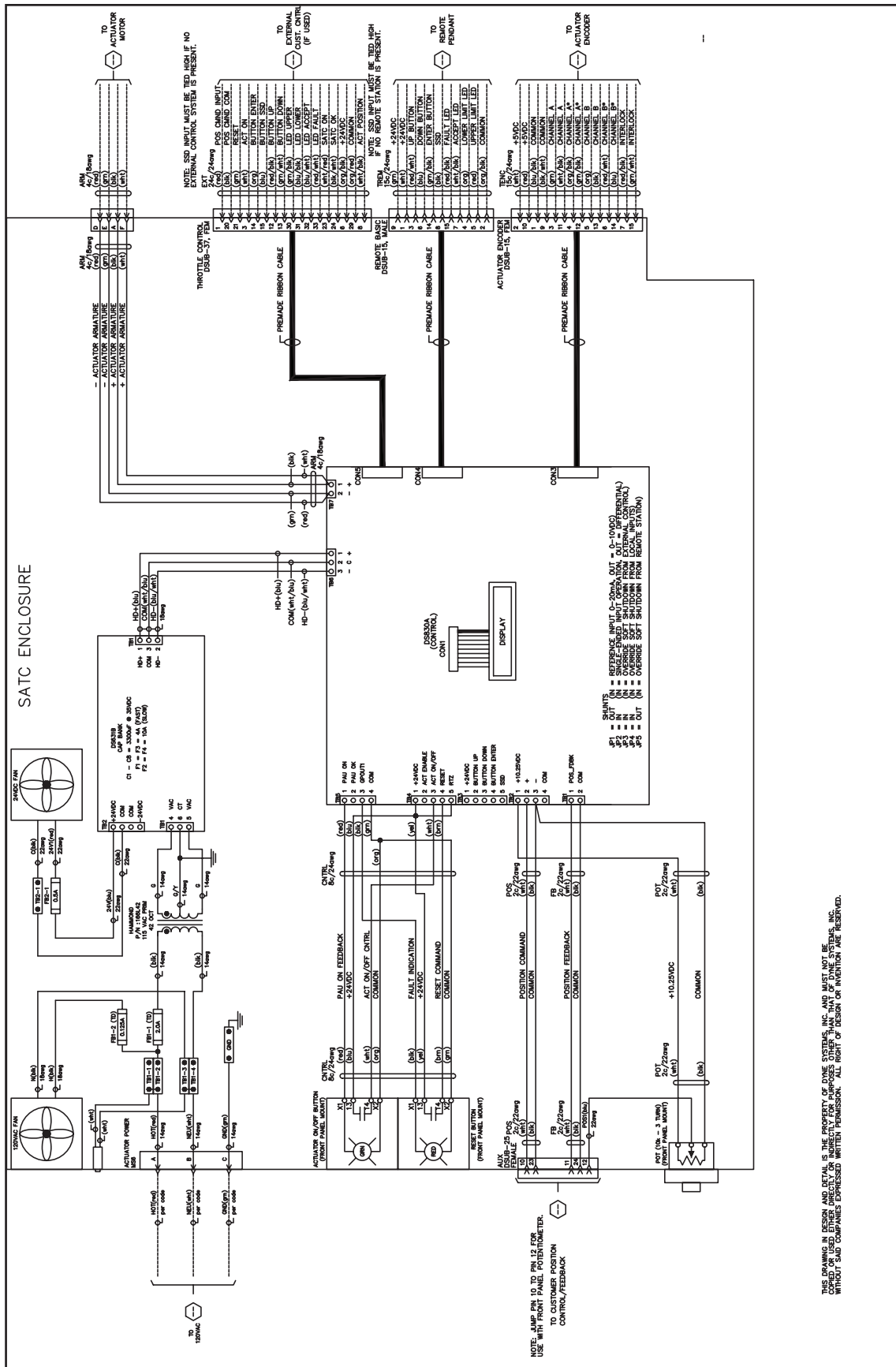

THIS DRAWING IN DESIGN AND DETAIL IS THE PROPERTY OF DYNE SYSTEMS, INC. AND MUST NOT BE COPIED OR USED EITHER DIRECTLY OR INDIRECTLY FOR PURPOSES OTHER THAN THAT OF DYNE SYSTEMS, INC. WITHOUT SAID COMPANIES EXPRESSED WRITTEN PERMISSION. ALL RIGHT OF DESIGN OR INVENTION ARE RESERVED.

## **APPENDIX C: ACRONYMS**

**°C - Degrees Centigrade**

**CW - Clockwise**

**CCW - Counter Clockwise**

**°F - Degrees Fahrenheit**

**GND - Ground**

**I/O - Input or Output**

**(i) - Input**

**(o) - Output**

**JP - Jumper**

**LCD - Liquid Crystal Display**

**LED - Light Emitting Diode**

**NC - Not Connected**

**NEC - National Electric Code**

**RTZ - Return To Zero**

**SATC - Standalone Throttle Controller**

**SSD - Soft Shutdown**

**VAC - Volts Alternating Current**

**VDC - Volts Direct Current**